

PT50-12

12Volt 50Ah

Specifications

Nominal Voltage(V) 12V

Nominal Capacity

10 hour rate (10A to 10.80V)	50Ah
5 hour rate (17A to 10.20V)	46Ah
1 hour rate (60A to 9.60V)	42.5Ah

Weight Approx. 15.5kg(34.18Lbs.)

Internal Resistance (at 1KHz) Approx. 7 mΩ

Maximum Discharge Current for

5 seconds: 500A

Charging Methods at 25°C (77° F)

Cycle use:

Charging Voltage 14.4 to 15.0V

Coefficient -5.0mV/°C/cell

Maximum Charging Current : 15A

Standby use:

Float Charging Voltage 13.5 to 13.8V

Coefficient -3.0mV/°C/cell

Operating Temperature Range

Charge -15°C (5°F) to 40°C (104°F)

Discharge -15°C (5°F) to 50°C (122°F)

Storage -15°C (5°F) to 40°C (104°F)

Design Life 12 years

Charge Retention (shelf life) at 20°C (68°F)

1 month 98%

3 month 94%

6 month 85%

Case Material ABS UL94 HB

Option: Flammability resistance of (UL94 V-0)

Terminal F11

Description of torque value of hard ware for the terminals:

Recommended torque value **M8: 7 N-m (71kgf-cm)**

Maximum allowable torque value **M8: 9 N-m (92kgf-cm)**



Dimensions

mm(inch)

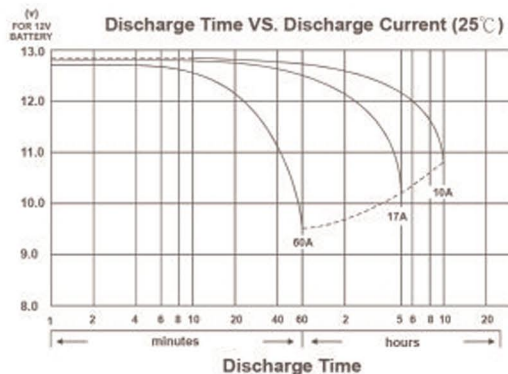
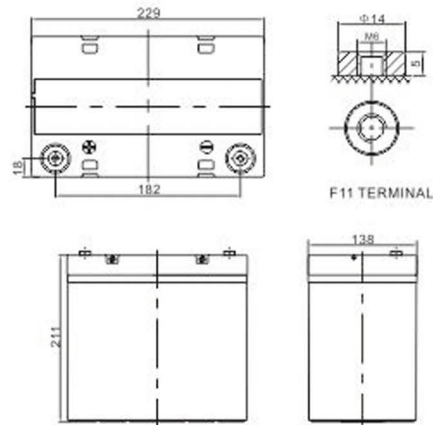

Effect of Temperature on Capacity 25°C(77°F)

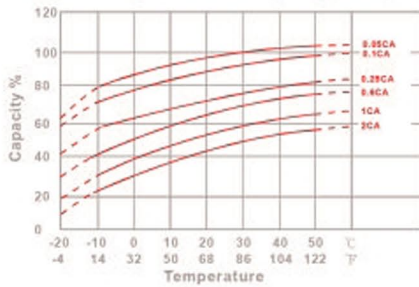

Capacity Retention Characteristic

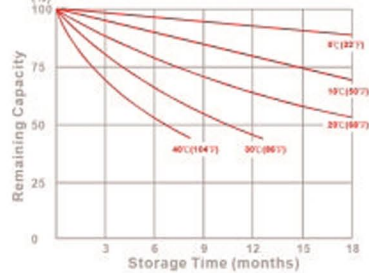

Trickle (or float) Service Life

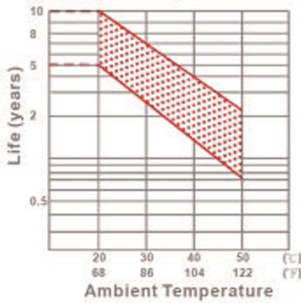

Cycle Service Life

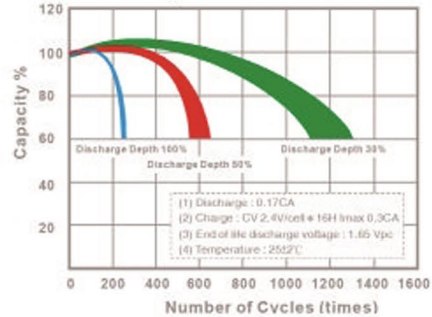

Constant Current Discharge Characteristics :A(25°C)

F.V/Time	5MIN	10MIN	15MIN	30MIN	1HR	2HR	3HR	4HR	5HR	8HR	10HR	20HR
1.60V	166.5	122.5	91.42	52.45	30.31	17.75	13.21	10.46	8.82	6.02	5.10	2.60
1.65V	160.4	118.4	88.68	51.35	29.73	17.45	13.01	10.32	8.71	5.95	5.05	2.57
1.70V	152.3	113.1	85.09	49.89	28.97	17.04	12.74	10.13	8.56	5.86	4.98	2.54
1.75V	141.7	106.0	80.27	47.91	27.94	16.50	12.37	9.86	8.36	5.74	4.88	2.50
1.80V	127.5	96.4	73.76	45.20	26.51	15.74	11.86	9.50	8.08	5.56	4.75	2.44
1.85V	108.4	83.41	64.80	41.35	24.48	14.65	11.12	8.97	7.68	5.31	4.56	2.35

Constant Power Discharge Characteristics : WPC(25°C)

F.V/Time	5MIN	10MIN	15MIN	30MIN	1HR	2HR	3HR	4HR	5HR	8HR	10HR	20HR
1.60V	282	208	160	95.3	56.7	33.6	25.2	20.1	17.0	11.8	10.0	5.12
1.65V	279	207	158	94.7	56.2	33.3	25.0	19.9	16.9	11.7	9.94	5.08
1.70V	268	200	153	92.5	54.9	32.6	24.5	19.6	16.6	11.5	9.81	5.02
1.75V	254	190	147	89.7	53.2	31.7	23.9	19.2	16.3	11.3	9.64	4.94
1.80V	232	176	137	85.5	50.8	30.4	23.0	18.5	15.8	11.0	9.39	4.83
1.85V	201	155	122	79.0	47.2	28.5	21.7	17.5	15.1	10.5	9.02	4.66

(Note) The above characteristics data are average values obtained within three charge/discharge cycle not the minimum values.